

版本	发行日期	发行原因	发行人
XA	2015-02-04	首版发行	victor

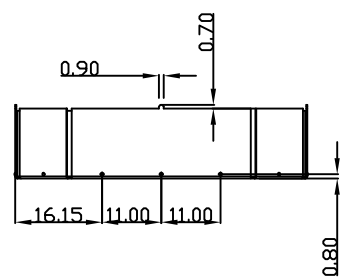
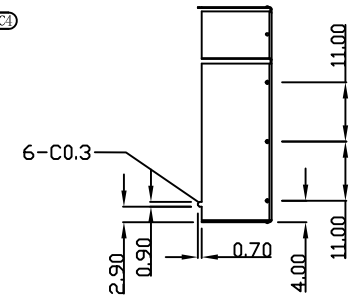
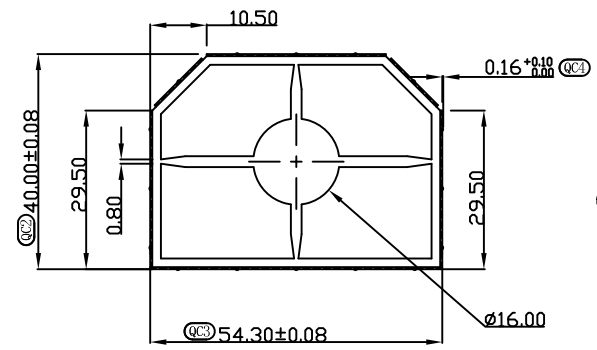
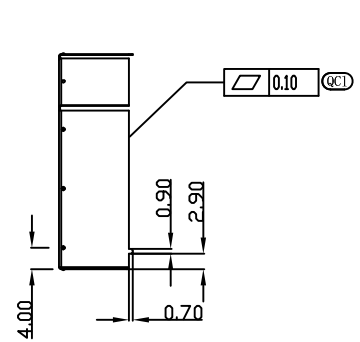
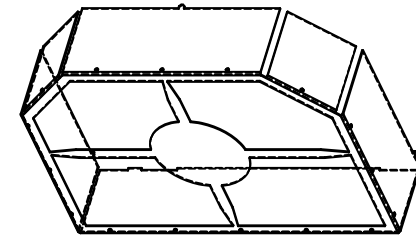
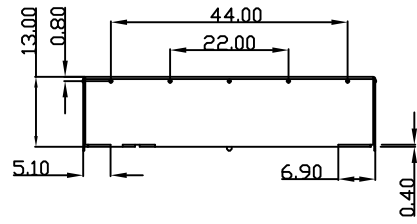

NOTES: UNLESS OTHERWISE SPECIFIED  
 1. ALL THE DIMENSIONS AND TOLERANCES SHOULD BE CONTROLLED ACCORDING TO HH3C-02015.  
 2. SCRATCHES OR COLLISION DAMAGES ON THE SURFACE ARE NOT ALLOWED.  
 3. REMOVE ALL BURRS AND SHARP EDGES, CLEAN THE OIL POLLUTION.  
 4. ALL THE INSIDE RADII OF BEND ARE R0.1.  
 5. ALL THE INSIDE ANGLE OF BEND IS 90°.  
 6. THE FRAME SHOULD BE ABLE TO MATCH WITH HH3C8.035.0106 CLOSELY.

材料: 洋白铜, T=0.20

与106配合

APPROVE	TITLE 5.8G RF SHIELD FRAME					佛山市寰威通信科技有限公司				
CHECK	PART NO. HT16-10N0105-001					GENERAL TOLERANCE			UNITS MM	SIZE A4
DRAW	REV XA	DATE 2015-02-04	DRAW Ben	CHECK Ben	APPROVE Victor	.X± 0.20	X.'± 2		SHEE 1 / 1	REV XA
						.XX± 0.10	.X'± 1	SCALE 1:1		
						.XXX± 0.05				