

1 2 3 4 5 6 7 8

版本	发行日期	发行原因	发行人
XA	2015-02-04	首版发行	victor

H  
G  
F  
E  
D  
C  
B  
A

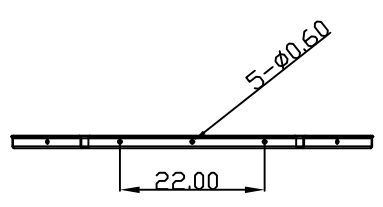
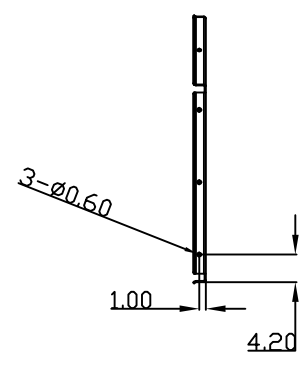
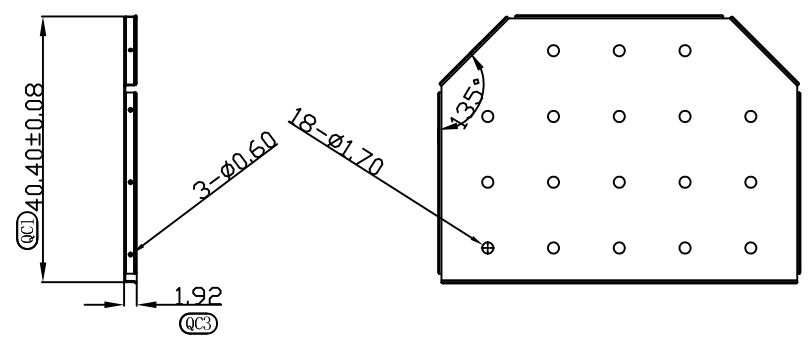
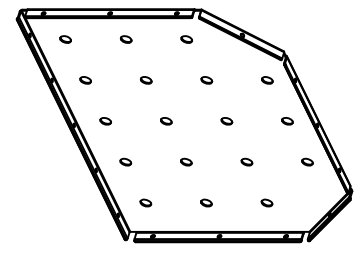
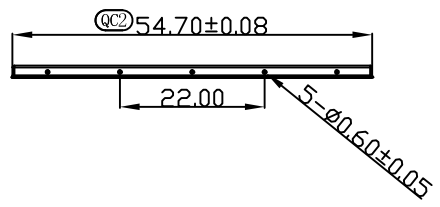

- NOTES: UNLESS OTHERWISE SPECIFIED
1. ALL THE DIMENSIONS AND TOLERANCES SHOULD BE CONTROLLED ACCORDING TO HH3C-02015.
  2. SCRATCHES OR COLLISION DAMAGES ON THE SURFACE ARE NOT ALLOWED.
  3. REMOVE ALL BURRS AND SHARP EDGES, CLEAN THE OIL POLLUTION.
  4. ALL THE INSIDE RADII OF BEND ARE R0.2.
  5. ALL THE INSIDE ANGLE OF BEND IS 90°.
  6. MIN BEND RELIEF.

材料:SUS304, T=0.20

与105配合

APPROVE	TITLE RF SHIELD COVER					佛山市寰威通信科技有限公司				
CHECK	PART NO. HT16-10S0106-001					GENERAL TOLERANCE			UNITS MM	SIZE A4
DRAW	REV	DATE	DRAW	CHECK	APPROVE	.X± 0.20	X.'± 2		SCALE 1:1	SHEE 1 / 1
	XA	2015-02-04	Ben	Ben	Victor	.XX± 0.10	.X'± 1			
						.XXX± 0.05				